

## **CENTRALIZER & SPACER SYSTEMS FOR THE DRILLING & CIVIL CONSTRUCTION INDUSTRIES**

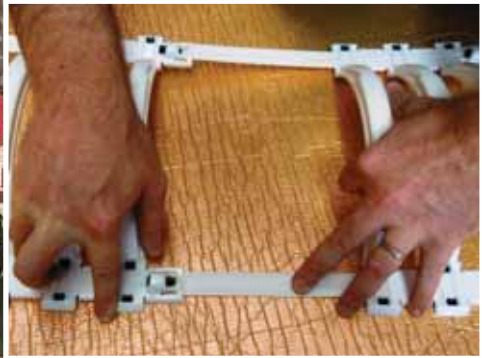

## About kwik-ZIP

kwik-ZIP Centraliser and Spacer Systems are used extensively in Production Drilling, Trenchless Pipeline Installation and Foundation and Ground Engineering applications.

Designed and developed by drilling professionals originally to solve production casing centralization challenges, the kwik-ZIP range has grown into a multiple industry series of innovative models that handle bar and pipe diameters from 18mm to greater than 1600 mm.

Manufactured from high grade thermoplastics with a unique injection moulded segment design, kwik-ZIP is recommended by numerous Regulatory Agencies and International Engineering Consulting Firms.

kwik-ZIP maintains a focus on price effectiveness, simplicity and rapid on-site assembly, to ensure that our systems deliver significant cost, time and operational advantages to our end user customers.

## kwik-ZIP Advantages

**Cost.** Real savings when multiple centralisers and spacers are required.

**Time.** Onsite assembly within seconds for smaller pipe diameters.

**Simplicity.** No specialist skills required to put together.

**Flexibility.** Various bow heights for different pipe/bar/borehole combinations.

**Resilience.** Engineered from high impact thermoplastic rated to 80 deg C (176 F), with no metal parts to corrode.

**Slip Prevention (HD Series).** Integrated rubber pads to lock onto pipe/casing.

**Curved Profile.** Low friction coefficient for easy pipe/casing insertion into casing/hole.

**Logistics.** Segmented design and packaging for low inventory and transport costs.

**Expertise.** Technical advice available on best kwik-ZIP model for your project

Selected companies that use kwik-ZIP include:

John Holland, South East Water, Melbourne Water, Rock Australia, Chevron, Dywidag Systems International, Sydney Water, Lane Christenson, DM Civil, Queensland Department of Natural Resources, Theiss, URS Corp, Water Corporation (WA), Boart Longyear, ADK Civil, Underground Services Australia, Westernport Water.

Markets served include Australasia, the United States of America, the United Kingdom, Continental Europe, the Middle East, and Central and South America.

Customers in the United States of America are serviced from our Michigan warehouse.

# HD Series

This model will centralize pipe and casing diameters of 110mm (4.33in) OD to greater than 1600mm (63in) OD.

It comes in bow heights of 30mm (1.18 in), 50mm (2 in), 75mm (3 in), and 100mm (4 in).

Its unique features include a curved bow spring with superior centralizing force.

Centralizing and spacing applications include, but are not limited to:

- Carrier pipe/conduit in horizontal cased crossing.
- Gravel packed well screen.
- Well production casing in borehole.
- Piles.

No special tools are required to assemble the HD Series.



## HD Series Table

Outside Dia of Pipe mm (Inches)	Number of Segments	Approx Setting Guide Position
110 (4.33)	2	0
<b>114.30 (4.50)</b>	<b>2</b>	<b>15</b>
<b>127.00 (5.00)</b>	<b>2</b>	<b>30</b>
<b>141.30 (5.563)</b>	<b>2</b>	<b>55</b>
160 (6.30)	2	85
<b>168.27 (6.625)</b>	<b>3</b>	<b>5</b>
180 (7.09)	3	20
200 (7.87)	3	40
<b>219.08 (8.625)</b>	<b>3</b>	<b>65</b>
250 (9.84)	4	25
<b>273.05 (10.75)</b>	<b>4</b>	<b>45</b>
<b>323.85 (12.75)</b>	<b>4</b>	<b>80</b>
<b>355.60 (14.00)</b>	<b>5</b>	<b>50</b>
<b>406.40 (16.00)</b>	<b>6</b>	<b>35</b>
<b>457.20 (18.00)</b>	<b>6</b>	<b>65</b>
<b>508.00 (20.00)</b>	<b>7</b>	<b>55</b>
<b>609.60 (24.00)</b>	<b>8</b>	<b>65</b>
650 (25.59)	9	50
710 (27.95)	9	70
800 (31.50)	10	75
900 (35.43)	12	60
1000 (39.37)	13	65
1200 (47.24)	17	45
1400 (55.12)	20	45
1600 (62.99)	22	50

For pipe installed in the horizontal position, it is recommended that the number of bows be maximised to support maximum load per spacer.

The following formula can be used to calculate the number of segments required per spacer rounded down to the nearest whole number.

$$[\text{Pipe OD in mm} \times 3.1428] \div 180 = \text{No. of Segments}$$

Worked example using a 710mm OD pipe:

$$[710 \times 3.1428] \div 180 = 12.397 \text{ or } 12 \text{ segments}$$

# GT Series

This model will centralize bar, pipe and nail diameters of 18mm (0.70 in) OD up to 65mm (2.56 in) OD.

It comes in bow heights of 10mm (0.39 in), 20mm (0.78 in), 30mm (1.18 in), and 40mm (1.57 in).

Its unique features include a wide bow and a simple integrated "cable tie" method of assembly.

Centralizing and spacing applications include, but are not limited to:

- Soil Nails.
- Rock Bolts.
- Anchors.
- Small diameter drop pipe.
- Down hole cameras, geophysical tools and other data collection devices.

No special tools are required to assemble the GT Series.

## GT Series Table

Bar / Pipe Dia mm (Inches)	Units per Centralizer
18mm - 29mm (0.70 inch - 1.14 inch)	2
29mm - 46mm (1.14 inch - 1.81 inch)	3
46mm - 65mm (1.81 inch - 2.56 inch)	4
Over 65mm (Over 2.56 inch)	Use 155 HT Series

Important: Check pre-assembled centralizer against bar diameter before tightening collar straps.

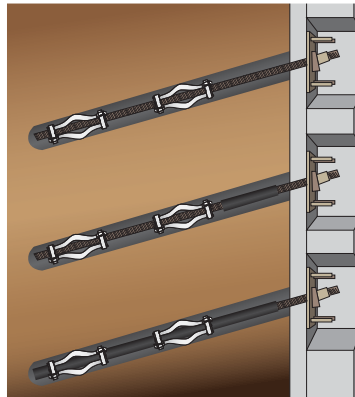

# 155 Series

This model will centralize casing and sheathing diameters of 58mm (2.28 in) OD up to 180mm (7.09 in) OD.

It comes in bow heights of 20mm (0.78 in), 30mm (1.18 in), and 50mm (2 in).

Its unique features include a flexible bow able to deflect to handle tight annulus settings.

Centralizing applications include, but are not limited to:

- Well production casing in borehole.
- Gravel packed well screen.
- Monitor well casing in borehole.
- Drop pipe in casing.
- Anchors and sheathing for ground engineering.

A 155 Series Setting Tool is required to assemble the 155 Series.

## 155 Series Table

Outside Dia of Casing mm (Inches)	Number of Segments	Approx Setting Guide Position
60 (2.362)	2	5
70 (2.756)	2	15
80 (3.150)	2	35
90 (3.543)	2	50
100 (3.937)	3	10
110 (4.331)	3	20
120 (4.724)	3	30
130 (5.118)	3	40
140 (5.512)	3	50
150 (5.905)	4	25
160 (6.299)	4	30
170 (6.693)	4	40
180 (7.087)	4	45



# 380 Series

This model will centralize casing diameters of 160mm (6.3 in) OD up to 760mm (29.9 in) OD.

It comes in bow heights of 30mm (1.18 in) and 50mm (2 in).

Its unique features include a flexible bow able to deflect to handle tight annulus settings.

Centralizing applications include, but are not limited to:

- Well production casing in borehole.
- Gravel packed well screen.
- Drop pipe in casing.

A 380 Series Setting Tool is required to assemble the 380 Series.



## 380 Series Table

Outside Dia of Casing mm (Inches)	Number of Segments	Approx Setting Guide Position
160 (6.299)	2	5
170 (6.693)	2	20
180 (7.087)	2	35
190 (7.480)	2	50
200 (7.874)	2	65
210 (8.268)	2	85
220 (8.661)	2	100
240 (9.449)	3	0
260 (10.236)	3	20
270 (10.630)	3	35
300 (11.811)	3	65
320 (12.598)	3	85
340 (13.386)	3	105
360 (14.173)	4	30
380 (14.961)	4	45
400 (15.748)	4	60
410 (16.142)	4	70
440 (17.323)	4	95
460 (18.110)	4	110
480 (18.898)	5	50
510 (20.079)	5	70
520 (20.472)	5	75
540 (21.260)	5	85
560 (22.047)	5	100
580 (22.835)	5	110
600 (23.622)	6	60
610 (24.016)	6	65
640 (25.197)	6	80
660 (25.984)	6	90
680 (26.772)	6	105
700 (27.559)	6	110
710 (27.953)	7	65
760 (29.921)	7	90

## What others are saying about kwik-ZIP

*"The GT-Series Centraliser is highly popular with our customers across a wide range of geotechnical projects for installation on both bar and sheathing. I think that's because the units provide a very simple, versatile, and economical centralizing solution, many times in settings where time and money are critical factors."*

**Steve Dube, Business Unit Manager, Dywidag Systems International**

*"These centralizers have provided excellent centering capability and a resulting grout job that meets all specifications. ... It's a good product and after recent failures with stainless centralizers, I am real happy to see a product with good strength properties available for contractors to use."*

**Jim Frazee, Hydrogeologist – St John River Water Management District, Florida USA.**

*"We use the HD series on our sewer installations on different pipe diameters. The curved bow spring allows easy insertion of the pipe into the casing. We also find that the rubber pads grip tightly onto the pipe to prevent slip. Because the units lock together easily Kwik-Zip saves us a lot of time."*

**Cliff Bailey, Project Manager, ADK Civil**

*"To date we have used well over a hundred thousand of Kwik-Zip's GT centralisers on our soil stabilization projects. We find the units to be quick and easy to assemble and versatile with different bar and hole sizes. I am happy with the product and would recommend it."*

**Raegan Rumbold, Project Manager, Rock Australia Mining and Civil**

*"Kwik-Zip's HD segments were delivered to site in compact boxes. In no time we had assembled multiple spacers on a 610 mm OD steel water main pipe run for friction reduction and centralization before we grouted. It was that simple."*

**Graeme Morton, Project Manager, Underground Services Australia**

*"When I first saw your product I knew it would be a huge success. I will forever be a customer and always speak highly of Kwik-ZIP products."*

**Don Huckfeldt, Owner, Huckfeldt Well Drilling, Napa, California**

# **kwik-*ZIP***<sup>®</sup>

For product prices and ordering information please contact [sales@kwikzip.com](mailto:sales@kwikzip.com)

AUSTRALASIAN SOCIETY  
FOR  
TRENCHLESS TECHNOLOGY



**adia**

**ADSC**

Member of the  
national  
ground water  
association<sup>®</sup>

Or visit us online for details of your nearest distributor at:

**[www.kwikzip.com](http://www.kwikzip.com)**

Quality Assured to ISO 9001

**Telephone** +61 8 9725 4678

**Facsimile** +61 8 9725 4700

**3 Barnard Street, Bunbury WA 6230 AUSTRALIA**

**US Warehouse: Traverse City, MI USA**